

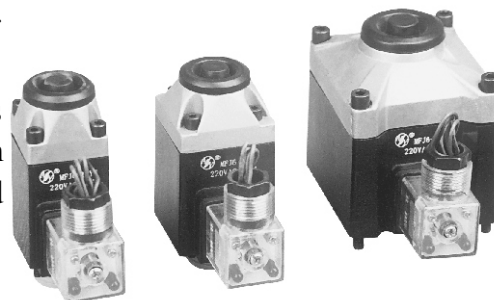

### Purpose

This dry type solenoid is applied to the control circuits of AC 50Hz control circuits, which voltage can reach 380V, as component of the hydraulic solenoid directional valve. This solenoid is permitted by BSO Company Ltd. in Germany, which is matched for NG6, NG10 of Rexroth bolt connected solenoid directional valve.



### Usual Service Conditions

- It can be installed randomly.
- There is no gas or dust which can corrupt metal or destroy nonconductor. Or, it will affect the products lifetime.
- The solenoids fit for the continuous duty system or intermittent periodic duty system.
- The reasonable wave range of supply voltage is between 85%—110% (any special requirements is possible) .
- The protection is IP65 class.

### Key Parameters

Code		MFJ6-18YC	MFJ6-27YC	MFJ6-54YC
Rated Voltage	(V)	110 220	110 220	110 220
Power Frequency	(Hz)	50	50	50
Rated Force	(N)	18	27	54
Rated Stroke	(mm)	2.8	2.8	3.6
Total Stroke	(mm)	≥6.1	≥6.1	≥7.8
Static Oil Pressure	(MPa)	10	16	16
Start VA	(VA)	≤154	≤200	≤480
Holding VA	(VA)	≤55	≤46	≤65
Operating Frequency	(T/h)	12000	12000	12000

### Purchase Code

Valve-Using Solenoids	AC	Design Code	Rated Force	Wet
MF	J	6	18/27/54	YC



## Stroke-Force Curve

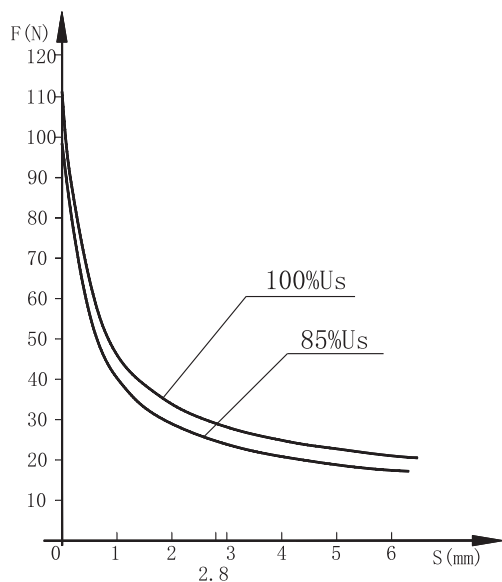

MFJ6-18YC

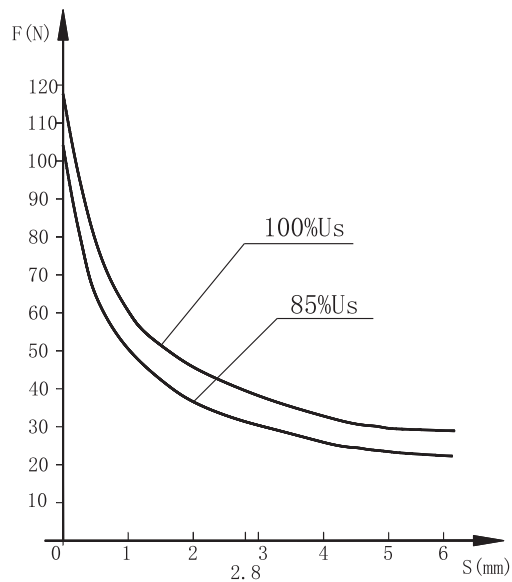

MFJ6-27YC

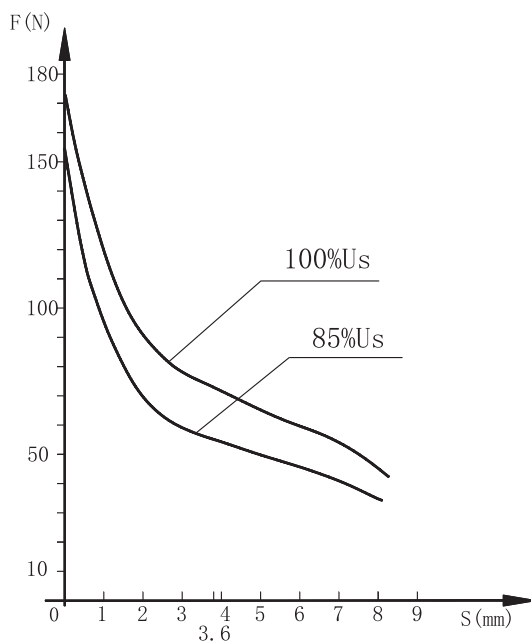

MFJ6-54YC



## Externality & Installation Dimensions

Product Code: MFJ6-18YC

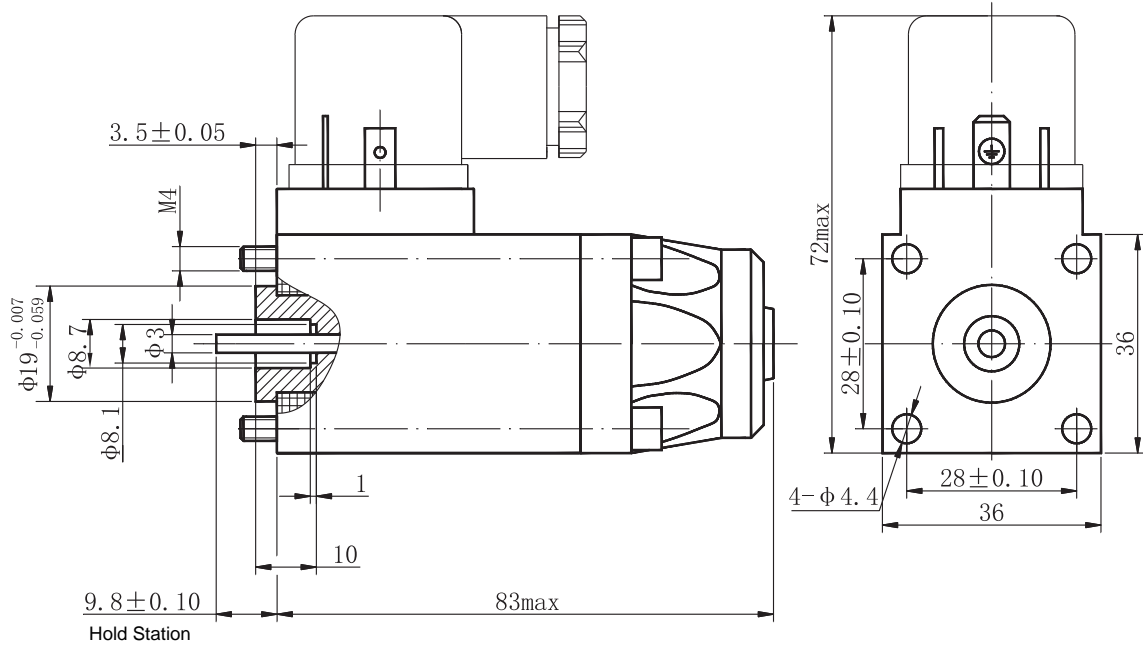

Product Code: MFJ6-27YC

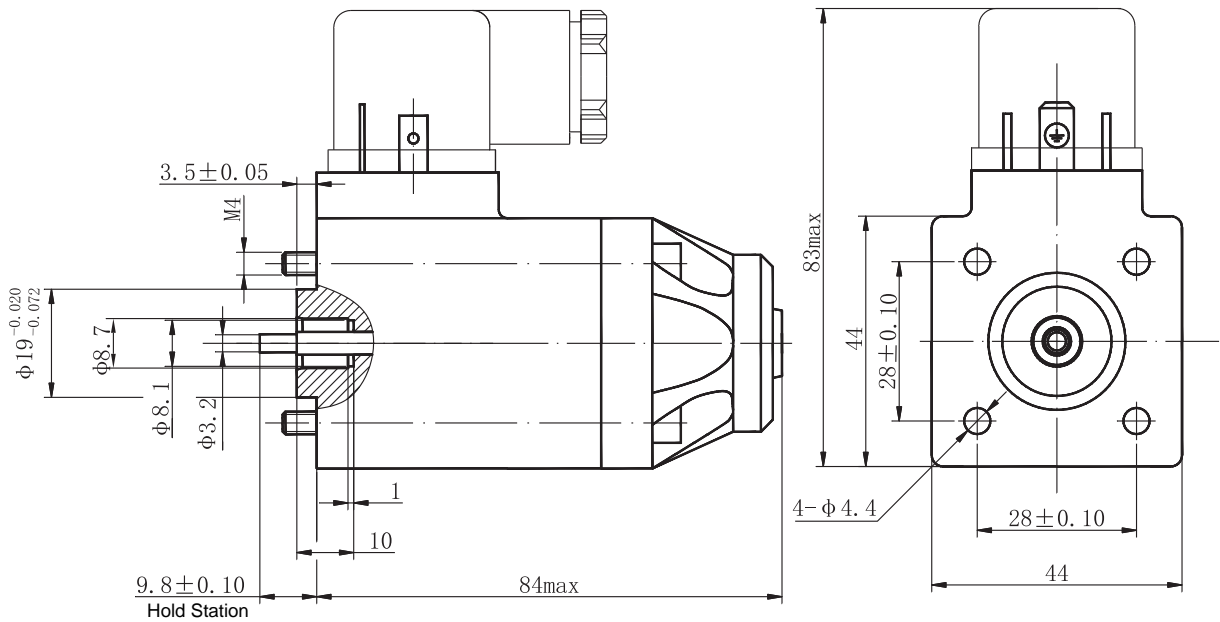



Product Code: MFJ6-54YC

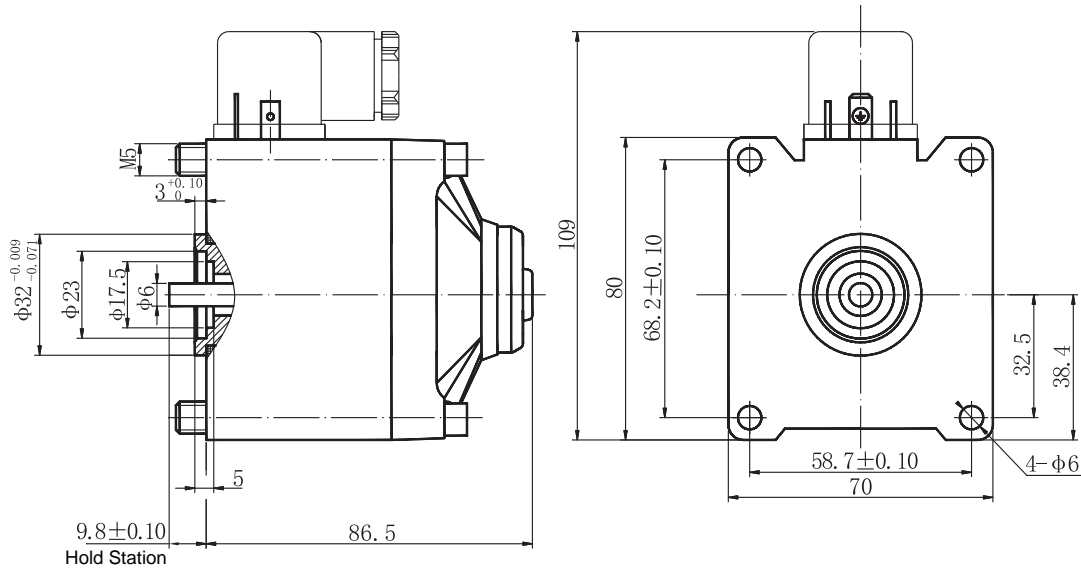

## Operating Notice

- The socket, which solenoids used, is according to ISO4400 standard. Including two specifications: indicator light & without light. You can choose according to your requirements. The voltage of the socket, with indicator light, must conform to the voltage of solenoid itself.
- The pushpin of the solenoid is used in adjustment or sometimes in emergency, but when the backpressure of the system is higher, please use screwdriver to push it, not strike it. The wallop can destroy the pushpin and the surface of the leading hole, or the solenoid will leak oil or cannot reposition.
- When the system ask for low noise, or the cleanliness of the oil can not make sure, or the wave range of the supply power is beyond common requirements, please use the AC internal rectifying solenoid.
- When solenoid is used in double directions, remember the solenoids cannot be energized at the same time in order to prevent the solenoids from burning.
- There is a protector of over-current between electrical control system and solenoid, in order to prevent the solenoid and the electrical component from burning in improper conditions.

## Explanation Of Sample

- If client have special requirements, we can adjust the connect dimension, the extended length of push pin, and the supply voltage between solenoids and valve body.
- Characteristic curve for reference only.
- The main performance parameter is obtained in the conditions of lab. Finally explanation and changing of the parameters by KAIDI.